

144 EXTREME REAR BUMPER KIT



P/N 2881941

APPLICATION

144 Axys

BEFORE YOU BEGIN

Read these instructions and check to be sure all parts and tools are accounted for. Please retain these installation instructions for future reference and parts ordering information.

KIT CONTENTS

This Kit includes:

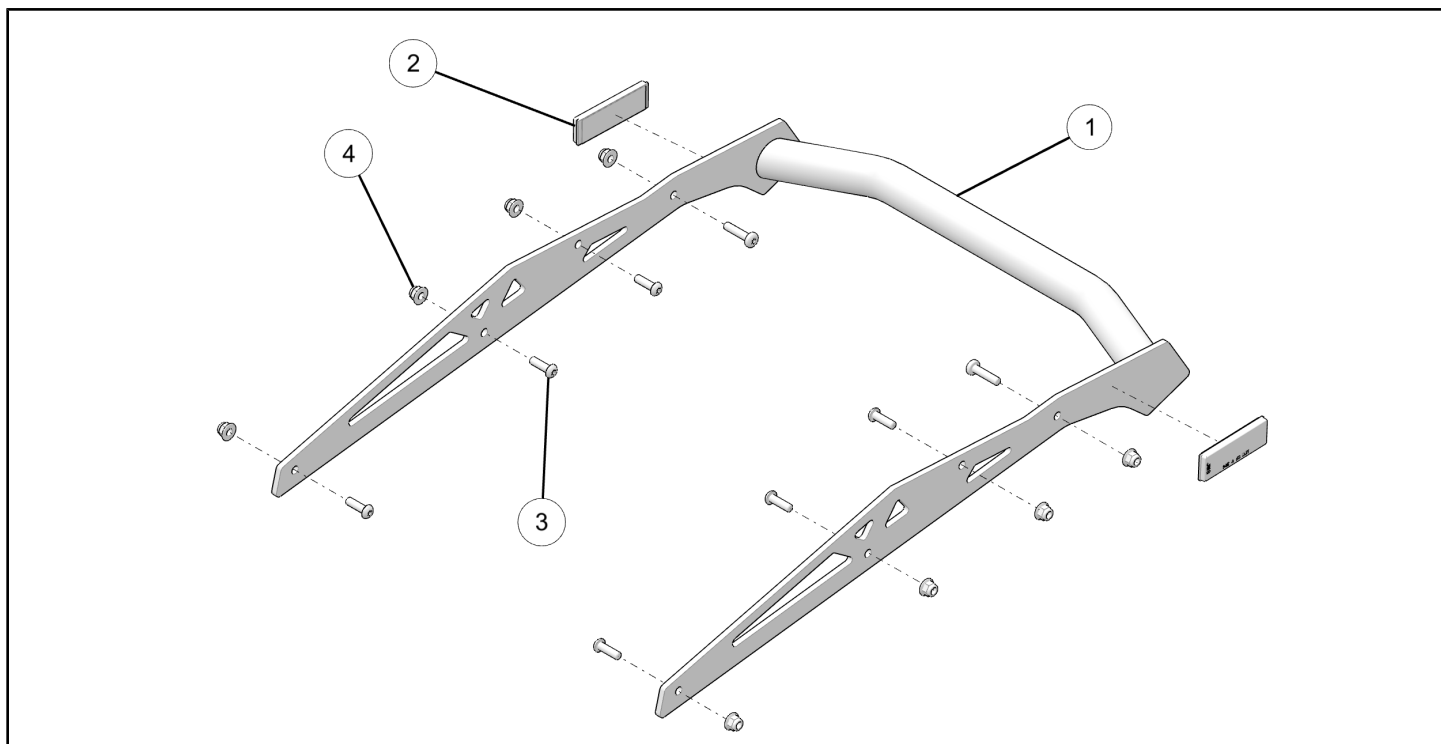

REF	QTY	PART DESCRIPTION	PART NUMBER
1	1	Extreme Rear Bumper Assembly	1022442
2	2	Red Reflector Assembly	2636502
3	8	Screw - M6 X 1.0 X 20	7518616
4	8	Nut - Hex Flange - M6 X 1.0	7547453
	1	Instructions	9927053

TOOLS REQUIRED

- T30 Torx® Bit
- 10mm Socket
- Ratchet Wrench
- Torque Wrench
- Isopropyl Alcohol or Other Suitable Cleaner/Degreaser
- Heat Gun

IMPORTANT

Your 144 EXTREME REAR BUMPER KIT is exclusively designed for your vehicle. Please read the installation instructions thoroughly before beginning. Installation is easier if the vehicle is clean and free of debris. For your safety, and to ensure a satisfactory installation, perform all installation steps correctly in the sequence shown.

ASSEMBLY TIME

Approximately 15 minutes

INSTALLATION INSTRUCTIONS

1. Remove four screws (A) and nuts (B) holding rear bumper (C) to tunnel using 10mm socket, ratchet wrench, and T30 Torx® wrench. Remove rear bumper (C) from tunnel.

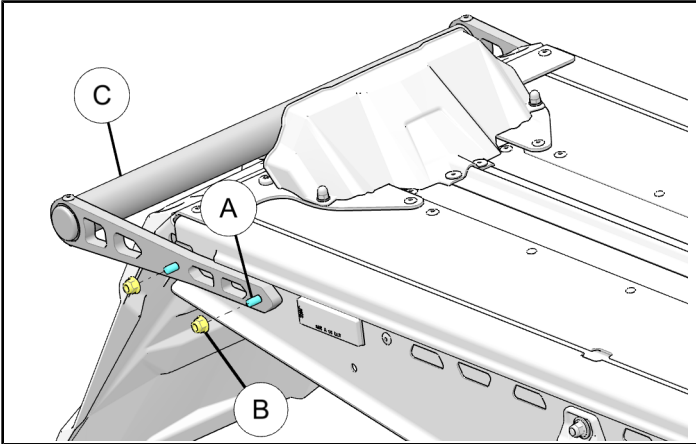

2. Warm the area around rear red reflector (D) using a heat gun, remove red reflector from tunnel. Clean remaining residue from tunnel using acetone or other suitable cleaner. Discard old reflector (D).

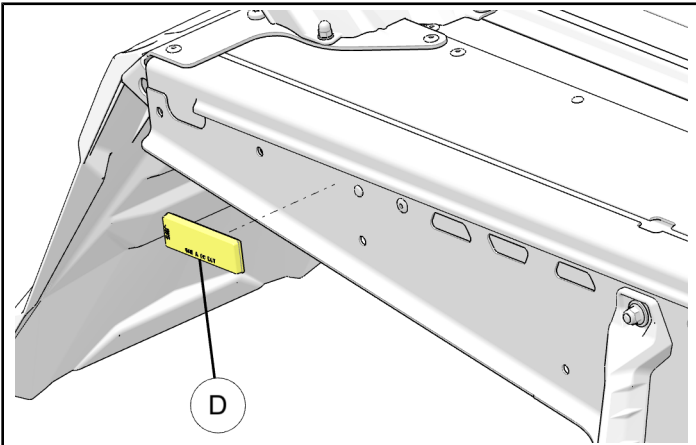

3. Clean extreme rear bumper (1) sides with Isopropyl alcohol or other suitable cleaner/degreaser. Install new reflector (2) on rear bumper (1).

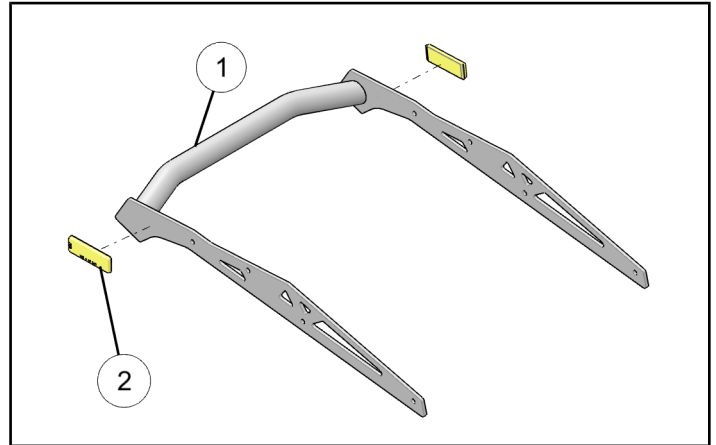

4. Install rear bumper (1) using screws (3) and nuts (4). Install screws with the nuts on outside of tunnel. Torque to specification.

TORQUE

7 ft. lbs. (9.4 Nm)

